

REVISIONS			
REV.	DESCRIPTION	DATE	APPROVED
-	NEW RELEASE	-	-
1	MOUNTING BRACKET WAS FABRICATED NOW PURCHASED. PLATE WASHERS WERE FABRICATED NOW PURCHASED.	4/22/2026	F. BRYANT

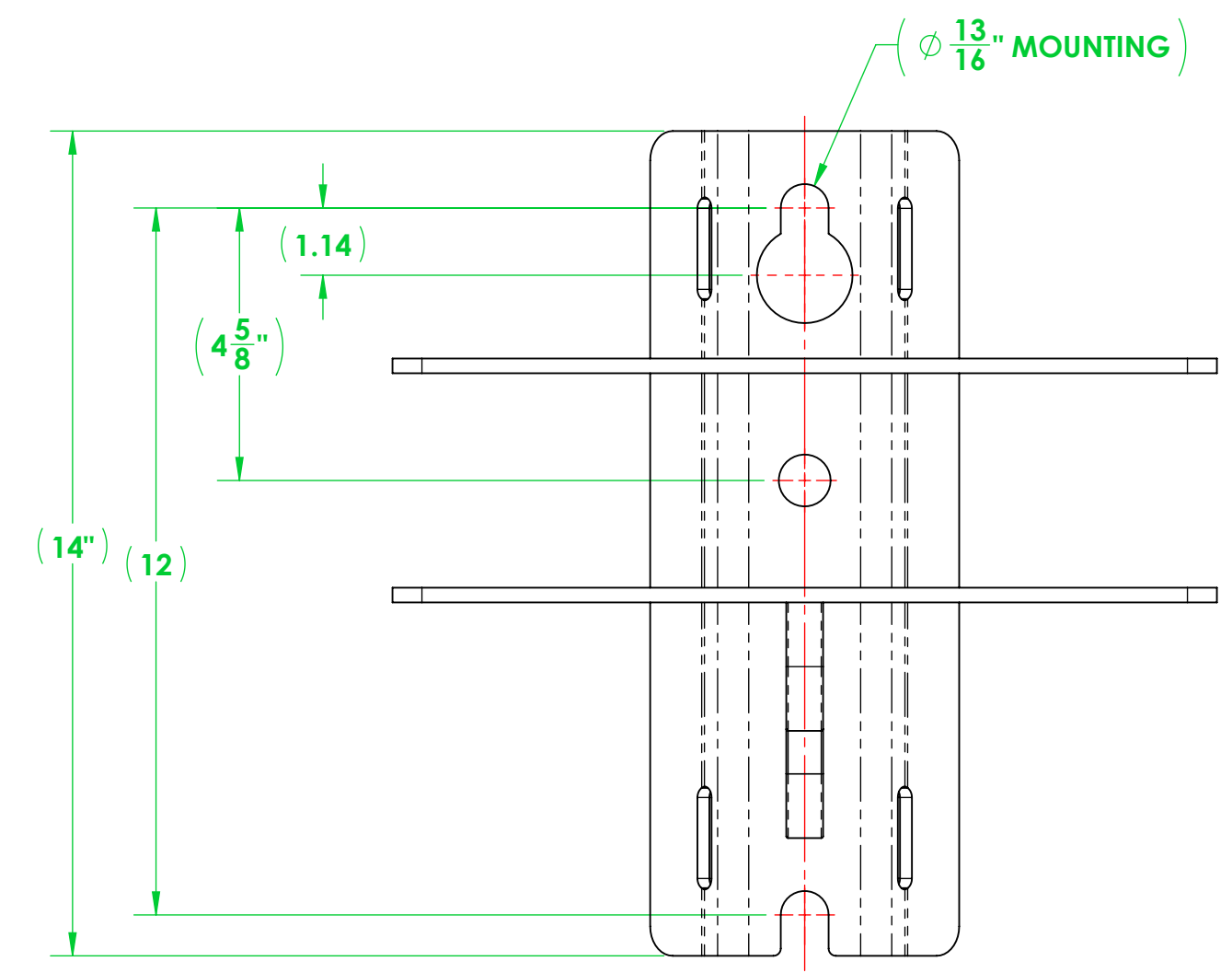

DETAIL A

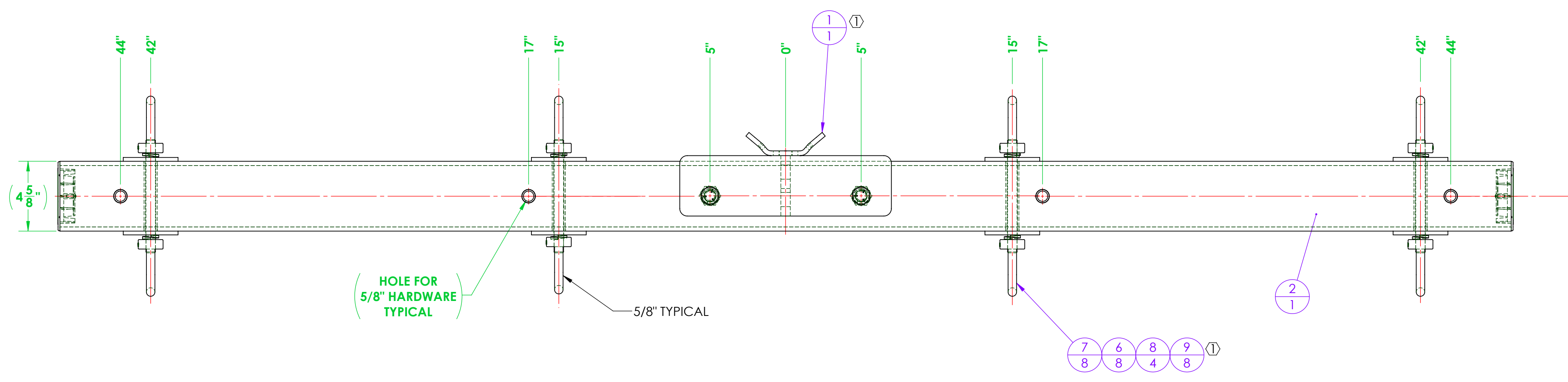
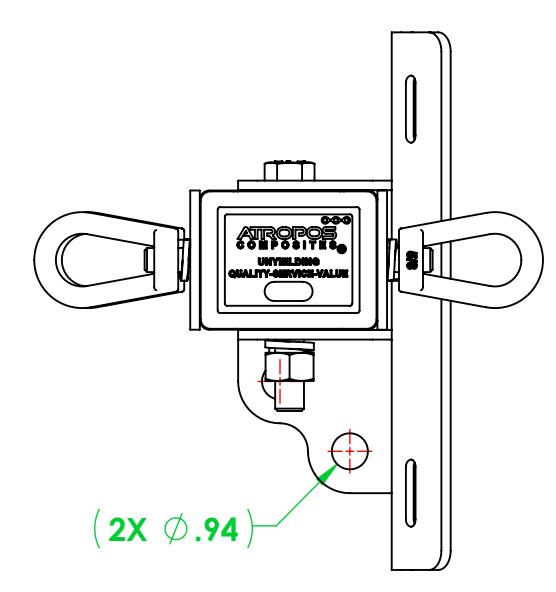
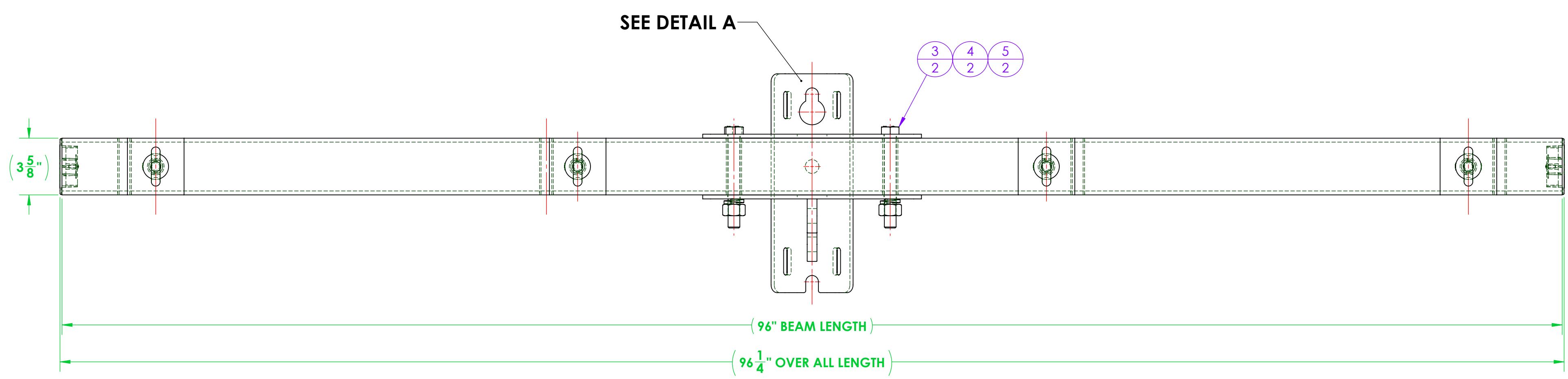

ITEM NO.	PART NUMBER	DESCRIPTION	QTY.
① 1	A700-0044	CROSSARM MOUNTING BRACKET, DEADEND, 3400 SERIES	1
2	3402A096-D312-4R08 CA	ASSEMBLY, 3402 DEADEND CROSSARM, 8'	1
3	A616-0020-02	BOLT, HEX, 3/4"-10 X 6.00" LONG, HOT DIPPED GALVANIZED STEEL, 1-1/8" DRIVE	2
4	A616-0042-01	LOCK WASHER, FOR 3/4" SCREW, 0.766" ID, 1.265" OD, 0.188" THICK, HOT-DIPPED GALVANIZED STEEL	2
5	A616-0019-02	EXTREME STRENGTH NUT, HEX, 3/4"-10, 2H, HOT-DIPPED GALVANIZED	2
6	A616-0042-02	LOCK WASHER, FOR 5/8" SCREW, 0.641" ID, 1.073" OD, 0.156" THICK, HOT-DIPPED GALVANIZED STEEL	8
7	A616-0017-02	EYENUT, 5/8"-11, GALVANIZED STEEL	8
8	A711-0044	ALL-THREAD, 5/8"-11 X 7.50" LONG, GALV. STEEL	4
① 9	A700-0049	WASHER, SQUARE, 3.625" X 3.625" X 0.25 THICK WITH 0.66 THRU HOLE	8

GENERAL NOTES	UNLESS OTHERWISE SPECIFIED	NAME	DATE
	DIMENSIONS ARE IN INCHES STANDARD TOLERANCES	DRAWN: F. BRYANT	10/16/2025
MATERIAL	FRACTIONAL: ±1/32	CHECKED	
	ANGULAR: MACHINED: ±0.5° BEND: ±2°	ENG APPR	
	TWO PLACE DECIMAL: ±0.03	MFG APPR	
	THREE PLACE DECIMAL: ±0.005	Q.A.	
INTERPRET GEOMETRIC TOLERANCING PER: ANSI Y14.5			
PROPERTY AND CONFIDENTIAL			
THE INFORMATION CONTAINED IN THIS DRAWING IS THE SOLE PROPERTY OF VECTURIO. ANY REPRODUCTION IN PART OR AS A WHOLE WITHOUT THE WRITTEN PERMISSION OF VECTURIO IS PROHIBITED.			
TITLE: ASSEMBLY, RUS, 3402 DEADEND CROSSARM WITH GAIN, 8'		SIZE: DWG. NO. D3402A096-D312-4R08	REV: 1
SCALE: 1:8		WEIGHT: 77.36	SHEET 1 OF 1

